



C8051F02X DEVELOPMENT KIT USER'S GUIDE

1. Kit Contents

The C8051F02x Development Kit contains the following items:

- C8051F020 Target Board
- Serial Adapter (RS232 to Target Board Debug Interface Protocol Converter)
- Silicon Laboratories IDE and Product Information CD-ROM. CD content includes:
 - Silicon Laboratories Integrated Development Environment (IDE)
 - Keil 8051 Development Tools (macro assembler, linker, evaluation 'C' compiler)
 - Installation Utility (SETUP.EXE)
 - Source code examples and register definition files
 - Documentation
- AC to DC Power Adapter
- RS232 Serial Cable
- 7" Ribbon Cable
- Quick-start Guide
- C8051F02x Development Kit User's Guide (this document)

2. Hardware Setup

The target board is connected to a PC running the Silicon Laboratories IDE via the Serial Adapter as shown in Figure 1.

1. Connect one end of the RS232 serial cable to a Serial (COM) Port on the PC.
2. Connect the other end of the RS232 serial cable to the DB-9 connector on the Serial Adapter.
3. Connect the Serial Adapter to the JTAG connector on the target board with the 10-pin ribbon cable.
4. Connect the AC/DC power adapter to power jack P1 on the target board.

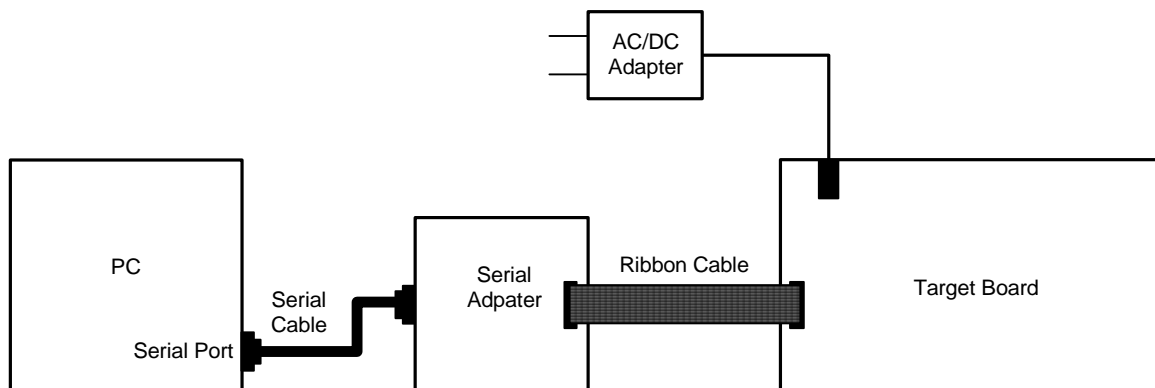

Figure 1. Hardware Setup

Note: The Reset switch on the target board is disabled when the serial adapter is connected to the target board. Use the **Reset** button in the Silicon Laboratories IDE toolbar to reset the target when connected to the Serial Adapter.

3. Software Setup

The included CD-ROM contains the Silicon Laboratories Integrated Development Environment (IDE), Keil software 8051 tools and additional documentation. Insert the CD-ROM into your PC's CD-ROM drive. An installer will automatically launch, allowing you to install the IDE software or read documentation by clicking buttons on the Installation Panel. If the installer does not automatically start when you insert the CD-ROM, run *autorun.exe* found in the root directory of the CD-ROM. Refer to the *readme.txt* file on the CD-ROM for the latest information regarding known IDE problems and restrictions.

4. Silicon Laboratories Integrated Development Environment

The Silicon Laboratories IDE integrates a source-code editor, source-level debugger and in-system Flash programmer. The use of third-party compilers and assemblers is also supported. This development kit includes the Keil Software A51 macro assembler, BL51 linker and evaluation version C51 'C' compiler. These tools can be used from within the Silicon Laboratories IDE.

4.1. System Requirements

The Silicon Laboratories IDE requirements:

- Pentium-class host PC running Microsoft Windows 95 or later, or Microsoft Windows NT or later.
- One available COM port.
- 64 MB RAM and 40 MB free HD space recommended.

4.2. Assembler and Linker

A full-version Keil A51 macro assembler and BL51 banking linker are included with the development kit and are installed during IDE installation. The complete assembler and linker reference manual can be found on-line under the **Help** menu in the IDE or in the "*SilabsMCU\hp*" directory (A51.pdf).

4.3. Evaluation C51 'C' Compiler

An evaluation version of the Keil C51 'C' compiler is included with the development kit and is installed during IDE installation. The evaluation version of the C51 compiler is the same as the full professional version except code size is limited to 4 kB and the floating point library is not included. The C51 compiler reference manual can be found under the **Help** menu in the IDE or in the "*SilabsMCU\hp*" directory (C51.pdf).

4.4. Using the Keil Software 8051 Tools with the Silicon Laboratories IDE

To perform source-level debugging with the IDE, you must configure the Keil 8051 tools to generate an absolute object file in the OMF-51 format with object extensions and debug records enabled. You may build the OMF-51 absolute object file by calling the Keil 8051 tools at the command line (e.g. batch file or make file) or by using the project manager built into the IDE. The default configuration when using the Silicon Laboratories IDE project manager enables object extension and debug record generation. Refer to Applications Note **AN104 - Integrating Keil 8051 Tools Into the Silicon Laboratories IDE** in the "*SiLabsMCU\Documentation\Appnotes*" directory on the CD-ROM for additional information on using the Keil 8051 tools with the Silicon Laboratories IDE.

To build an absolute object file using the Silicon Laboratories IDE project manager, you must first create a project. A project consists of a set of files, IDE configuration, debug views, and a target build configuration (list of files and tool configurations used as input to the assembler, compiler, and linker when building an output object file).

The following sections illustrate the steps necessary to manually create a project with one or more source files, build a program and download the program to the target in preparation for debugging. (The IDE will automatically create a single-file project using the currently open and active source file if you select **Build/Make Project** before a project is defined.)

4.4.1. Creating a New Project

1. Select **Project->New Project** to open a new project and reset all configuration settings to default.
2. Select **File->New File** to open an editor window. Create your source file(s) and save the file(s) with a recognized extension, such as .c, .h, or .asm, to enable color syntax highlighting.
3. Right-click on “New Project” in the **Project Window**. Select **Add files to project**. Select files in the file browser and click Open. Continue adding files until all project files have been added.
4. For each of the files in the **Project Window** that you want assembled, compiled and linked into the target build, right-click on the file name and select **Add file to build**. Each file will be assembled or compiled as appropriate (based on file extension) and linked into the build of the absolute object file.

Note: If a project contains a large number of files, the “Group” feature of the IDE can be used to organize. Right-click on “New Project” in the **Project Window**. Select **Add Groups to project**. Add pre-defined groups or add customized groups. Right-click on the group name and choose **Add file to group**. Select files to be added. Continue adding files until all project files have been added.

4.4.2. Building and Downloading the Program for Debugging

1. Once all source files have been added to the target build, build the project by clicking on the **Build/Make Project** button in the toolbar or selecting **Project->Build/Make Project** from the menu.

Note: After the project has been built the first time, the **Build/Make Project** command will only build the files that have been changed since the previous build. To rebuild all files and project dependencies, click on the **Rebuild All** button in the toolbar or select **Project->Rebuild All** from the menu.

2. C8051F02x family devices use the JTAG debug interface. You must select **JTAG** in the **Options->Debug Interface** menu to enable connection to C8051F02x target devices. Click the **Connect** button in the toolbar or select **Debug->Connect** from the menu to connect to the device.
3. Download the project to the target by clicking the **Download Code** button in the toolbar.

Note: To enable automatic downloading if the program build is successful select **Enable automatic connect/download after build** in the **Project->Target Build Configuration** dialog. If errors occur during the build process, the IDE will not attempt the download.

4. Save the project when finished with the debug session to preserve the current target build configuration, editor settings and the location of all open debug views. To save the project, select **Project->Save Project As...** from the menu. Create a new name for the project and click on **Save**.



5. Example Source Code

Example source code and register definition files are provided in the “*SiLabsMCU\Examples\C8051F02x*” directory during IDE installation. These files may be used as a template for code development. Example applications include a blinking LED example which configures the green LED on the target board to blink at a fixed rate.

5.1. Register Definition Files

Register definition files *C8051F020.inc* and *C8051F020.h* define all SFR registers and bit-addressable control/status bits. They are installed into the “*SiLabsMCU\Examples\C8051F02x*” directory during IDE installation. The register and bit names are identical to those used in the C8051F02x data sheet. Both register definition files are also installed in the default search path used by the Keil Software 8051 tools. Therefore, when using the Keil 8051 tools included with the development kit (A51, C51), it is not necessary to copy a register definition file to each project’s file directory.

5.2. Blinking LED Example

The example source files *blink.asm* and *blink.c* show examples of several basic C8051F02x functions. These include; disabling the watchdog timer (WDT), configuring the Port I/O crossbar, configuring a timer for an interrupt routine, initializing the system clock, and configuring a GPIO port. When compiled/assembled and linked this program flashes the green LED on the C8051F020 target board about five times a second using the interrupt handler with a C8051F020 timer.

6. Target Board

The C8051F02x Development Kit includes a target board with a C8051F020 device pre-installed for evaluation and preliminary software development. Numerous input/output (I/O) connections are provided to facilitate prototyping using the target board. Refer to Figure 2 for the locations of the various I/O connectors.

P1	Power connector (accepts input from 7 to 15 VDC unregulated power adapter)
J1	Connects SW2 to P3.7 pin
J3	Connects LED D3 to P1.6 pin
J4	JTAG connector for Serial Adapter interface
J5	DB-9 connector for UART0 RS232 interface
J6	Jumper to connect UART0 TX (P0.0) to DB9
J9	Jumper to connect UART0 RX (P0.1) to DB9
J11	Analog loopback connector
J12-J19	Port 0 - 7 connectors
J20	Analog I/O terminal block
J22	VREF connector
J23	VDD Monitor Disable
J24	96-pin Expansion I/O connector

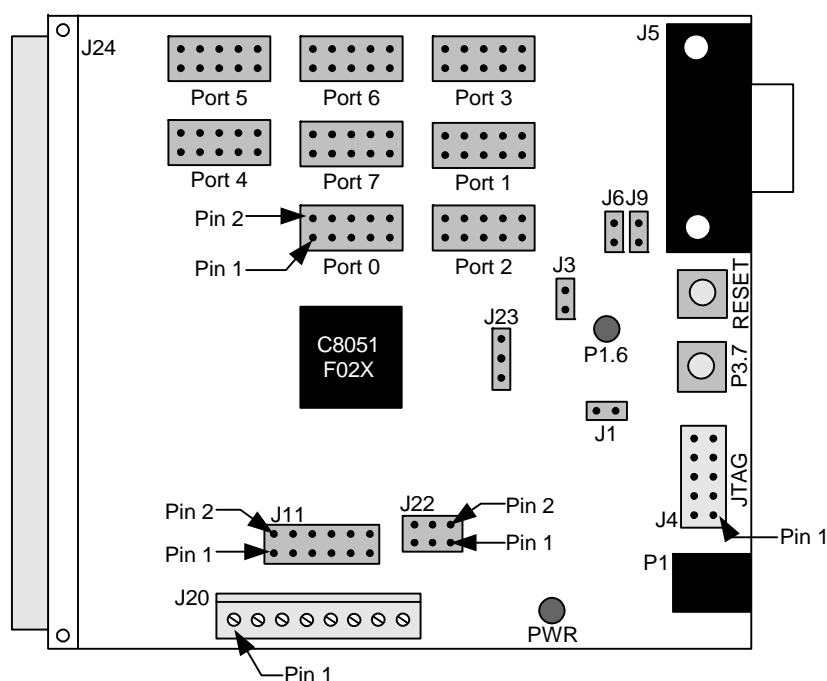

Figure 2. C8051F020 Target Board

6.1. System Clock Sources

The C8051F020 device installed on the target board features a calibrated programmable internal oscillator which is enabled as the system clock source on reset. After reset, the internal oscillator operates at a frequency of 2 MHz ($\pm 2\%$) by default but may be configured by software to operate at other frequencies. Therefore, in many applications an external oscillator is not required. However, an external 22.1184 MHz crystal is installed on the target board for additional applications. Refer to the C8051F02x data sheet for more information on configuring the system clock source.

6.2. Switches and LEDs

Two switches are provided on the target board. Switch SW1 is connected to the RESET pin of the C8051F020. Pressing SW1 puts the device into its hardware-reset state. Switch SW2 is connected to the C8051F020's general purpose I/O (GPIO) pin through jumpers. Pressing SW2 generates a logic low signal on the port pin. Remove the shorting block from the jumper to disconnect SW2 from the port pins. The port pin signal is also routed to a pin on the J24 I/O connector. See Table 1 for the port pins and jumpers corresponding to each switch.

Two LEDs are also provided on the target board. The red LED labeled PWR is used to indicate a power connection to the target board. The green LED labeled with a port pin name is connected to the C8051F020's GPIO pin through jumpers. Remove the shorting block from the jumper to disconnect the LED from the port pin. The port pin signal is also routed to a pin on the J24 I/O connector. See Table 1 for the port pins and jumpers corresponding to each LED.

Description	I/O	Jumper
SW1	Reset	none
SW2	P3.7	J1
Green LED	P1.6	J3
Red LED	PWR	none

Table 1. Target Board I/O Descriptions

6.3. Target Board JTAG Interface (J4)

The JTAG connector (J4) provides access to the JTAG pins of the C8051F020. It is used to connect the Serial Adapter to the target board for in-circuit debugging and Flash programming. Table 2 shows the JTAG pin definitions.

Pin #	Description
1	+3 VD (+3.3 VDC)
2, 3, 9	GND (Ground)
4	TCK
5	TMS
6	TDO
7	TDI
8, 10	Not Connected

Table 2. JTAG Connector Pin Descriptions

6.4. Serial Interface (J5)

A RS232 transceiver circuit and DB-9 (J5) connector are provided on the target board to facilitate serial connections to UART0 of the C8051F020. The TX, RX, RTS and CTS signals of UART0 may be connected to the DB-9 connector and transceiver by installing shorting blocks on jumpers J6, J8, J9 and J10.

- J6 - Install shorting block to connect UART0 TX (P0.0) to transceiver.
- J9 - Install shorting block to connect UART0 RX (P0.1) to transceiver.
- J8 - Install shorting block to connect UART0 RTS (P4.0) to transceiver.
- J10 - Install shorting block to connect UART0 CTS (P4.1) to transceiver.

6.5. Analog I/O (J11, J20)

Several C8051F020 analog signals are routed to the J20 terminal block and the J11 jumper block. Jumper block J11 provides the ability to connect DAC0 and DAC1 outputs to several different analog inputs by installing a shorting block between a DAC output and an analog input on adjacent pins of J11. Refer to Table 3 for J20 terminal block connections and Table 4 for J11 pin definitions.

Pin #	Description
1	CP0+
2	CP0-
3	DAC0
4	DAC1
5	AIN0.0
6	AIN0.1
7	VREF0
8	ADND (Analog Ground)

Table 3. J20 Terminal Block Pin Descriptions

Pin #	Description
1	CP0+
2	CP0-
3	DAC0
4	DAC1
5	CP1+
6	CP1-
7	AIN0.0
8	AIN0.1
9	DAC0
10	DAC1
11	AIN0.6
12	AIN0.7

Table 4. J11 Jumper Block Pin Descriptions

6.6. PORT I/O Connectors (J12 - J19)

In addition to all port I/O signals being routed to the 96-pin expansion connector, each of the eight parallel ports of the C8051F020 has its own 10-pin header connector. Each connector provides a pin for the corresponding port pins 0-7, +3.3 VDC and digital ground. Table 5 defines the pins for the port connectors. The same pin-out order is used for all of the port connectors.

Pin #	Description
1	Pn.0
2	Pn.1
3	Pn.2
4	Pn.3
5	Pn.4
6	Pn.5
7	Pn.6
8	Pn.7
9	+3 VD (+3.3 VDC)
10	GND (Ground)

Table 5. J12- J19 Port Connector Pin Descriptions

6.7. VDD Monitor Disable Jumper (J23)

The VDD Monitor of the C8051F020 may be disabled by moving the shorting block on J23 from pins 1-2 to pins 2-3, as shown in Figure 3.

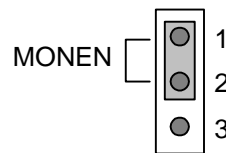

Figure 3. VDD Monitor Hardware Setup

6.8. Expansion I/O Connector (J24)

The 96-pin expansion I/O connector J24 is used to connect daughter boards to the main target board. J24 provides access to many C8051F020 signal pins. Pins for +3 V, digital ground, analog ground and the unregulated power supply (VUNREG) are also available. The VUNREG pin is connected directly to the unregulated +V pin of the P1 power connector. See Table 6 for a complete list of pins available at J24.

The J24 socket connector is manufactured by Hirose Electronic Co. Ltd, part number PCN13-96S-2.54DS, Digi-Key part number H7096-ND. The corresponding plug connector is also manufactured by Hirose Electronic Co. Ltd, part number PCN10-96P-2.54DS, Digi-Key part number H5096-ND.

Pin #	Description	Pin #	Description	Pin #	Description
A-1	+3 VD2 (+3.3 VDC)	B-1	DGND (Digital Gnd)	C-1	XTAL1
A-2	MONEN	B-2	P1.7	C-2	P1.6
A-3	P1.5	B-3	P1.4	C-3	P1.3
A-4	P1.2	B-4	P1.1	C-4	P1.0
A-5	P2.7	B-5	P2.6	C-5	P2.5
A-6	P2.4	B-6	P2.3	C-6	P2.2
A-7	P2.1	B-7	P2.0	C-7	P3.7
A-8	P3.6	B-8	P3.5	C-8	P3.4
A-9	P3.3	B-9	P3.2	C-9	P3.1
A-10	P3.0	B-10	P0.7	C-10	P0.6
A-11	P0.5	B-11	P0.4	C-11	P0.3
A-12	P0.2	B-12	P0.1	C-12	P0.0
A-13	P7.7	B-13	P7.6	C-13	P7.5
A-14	P7.4	B-14	P7.3	C-14	P7.2
A-15	P7.1	B-15	P7.0	C-15	P6.7
A-16	P6.6	B-16	P6.5	C-16	P6.4
A-17	P6.3	B-17	P6.2	C-17	P6.1
A-18	P6.0	B-18	P5.7	C-18	P5.6
A-19	P5.5	B-19	P5.4	C-19	P5.3
A-20	P5.2	B-20	P5.1	C-20	P5.0
A-21	P4.7	B-21	P4.6	C-21	P4.5
A-22	P4.4	B-22	P4.3	C-22	P4.2
A-23	P4.1	B-23	P4.0	C-23	TMS
A-24	TCK	B-24	TDI	C-24	TDO
A-25	/RST	B-25	DGND (Digital Gnd)	C-25	VUNREG
A-26	AGND (Analog Gnd)	B-26	DAC1	C-26	DAC0
A-27	CP1-	B-27	CP1+	C-27	CP0-
A-28	CP0+	B-28	VREF	C-28	VREFD
A-29	VREF0	B-29	VREF1	C-29	AIN0.7
A-30	AIN0.6	B-30	AIN0.5	C-30	AIN0.4
A-31	AIN0.3	B-31	AIN0.2	C-31	AIN0.1
A-32	AIN0.0	B-32	AGND (Analog Gnd)	C-32	AV+ (+3.3 VDC Analog)

Table 6. J24 Pin Descriptions

6.9. VREF Connector (J22)

The VREF jumper block, J22, can be used to connect the VREF (Voltage Reference) output of the C8051F020 to any (or all) of its voltage reference inputs. Install shorting blocks on J22 in the following manner:

- 1-2 to connect VREF to VREFD
- 3-4 to connect VREF to VREF0
- 5-6 to connect VREF to VREF1

7. Serial Adapter

The Serial Adapter provides the interface between the PC's RS232 serial port and the C8051F02x's in-system debug/programming circuitry. The Serial Adapter connects to the C8051F020 JTAG debug interface on the target board using the 10-pin connector on the Serial Adapter labeled "JTAG", see Figure 4. (The Serial Adapter supports both Silicon Laboratories JTAG and C2 debug interfaces.). All Serial Adapters may be powered from the target board, but the EC1 and EC2 Serial Adapter units cannot provide power to the target board. Table 7 shows the pin definitions for the Serial Adapter's JTAG connector.

Notes:

1. When powering the Serial Adapter via the JTAG connector, the input voltage to the JTAG connector's power pin must be 3.0 to 3.6 VDC. Otherwise, the Serial Adapter must be powered directly by connecting the AC/DC adapter to the Serial Adapter's DC power jack.
2. The Serial Adapter requires a target system clock of 32 Khz or greater.

Pin #	Description
1	3.0 to 3.6 VDC Input
2	GND (Ground)
4	TCK (C2DAT)
5	TMS
6	TDO
7	TDI (C2CLK)
3,8,9,10	Not Connected

Table 7. JTAG/DEBUG Connector Pin Descriptions

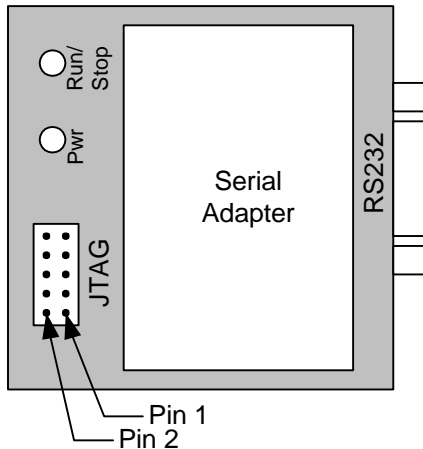

Figure 4. Serial Adapter JTAG/DEBUG Connector

Contact Information

Silicon Laboratories Inc.
4635 Boston Lane
Austin, TX 78735
Tel: 1+(512) 416-8500
Fax: 1+(512) 416-9669
Toll Free: 1+(877) 444-3032
Email: productinfo@silabs.com
Internet: www.silabs.com

The information in this document is believed to be accurate in all respects at the time of publication but is subject to change without notice. Silicon Laboratories assumes no responsibility for errors and omissions, and disclaims responsibility for any consequences resulting from the use of information included herein. Additionally, Silicon Laboratories assumes no responsibility for the functioning of undescribed features or parameters. Silicon Laboratories reserves the right to make changes without further notice. Silicon Laboratories makes no warranty, representation or guarantee regarding the suitability of its products for any particular purpose, nor does Silicon Laboratories assume any liability arising out of the application or use of any product or circuit, and specifically disclaims any and all liability, including without limitation consequential or incidental damages. Silicon Laboratories products are not designed, intended, or authorized for use in applications intended to support or sustain life, or for any other application in which the failure of the Silicon Laboratories product could create a situation where personal injury or death may occur. Should Buyer purchase or use Silicon Laboratories products for any such unintended or unauthorized application, Buyer shall indemnify and hold Silicon Laboratories harmless against all claims and damages.

Silicon Laboratories and Silicon Labs are trademarks of Silicon Laboratories Inc.

Other products or brandnames mentioned herein are trademarks or registered trademarks of their respective holders.